

I/424e



## BIZERBA | SYSTEM CLASS

# SC-H 800 T-E

### NEW! BIZERBA LINERLESS PRINTER

- **More labels**  
With the same roll size.
- **Fewer roll changes** with high customer frequency.
- **Safe, hygienic bond of the shopping bag** – no hazard caused by metal staples.
- **Less waste – no backing paper.**  
Helps protect the environment and save energy costs.
- **Only with Bizerba Linerless: Label with adhesive-free grip edge.**



→ ELECTRONIC SYSTEM SCALE WITH CUSTOMER RECEIPT AND LABEL PRINTER.



# WHO PRINTS RECEIPTS AND LABELS WITH JUST ONE KEYSTROKE?

## TECHNICAL DATA



→ Weighing range (kg)	6 15 30 3/6 <sup>1)</sup> 6/15 <sup>1)</sup> 15/30 <sup>1)</sup> 15b 30b
→ Division (g)	2 5 10 1/2 2/5 5/10 0.005 0.01
→ Minimum load (g)	40 100 200 20 40 100 0.1 0.2
→ Maximum tare load (kg)	-6 -15 -30 -6 -15 -30 -15lb -30lb Automatic scale zero, zero key programmable.

→ **Display** LCD- Dot matrix display, Numbers of characters for article text: approx. 35, Number of lines for programming: 6, Weight indication: 4 or 5 digits, Indication of basic price: 6 digits, Indication of sales price: 7 digits, Tare indication: 4 or 5 digits

→ **Keyboard** Tactile keyboard, freely programmable, 84 keys, thereof 30 function keys and 54 direct PLU keys and further function keys, captionable direct keys: 30/54 (optional), add-on frame with 24 self service keys can be mounted on operating keyboard (optional)

→ **Programmable data per PLU:** Basic/unit price, product description up to 500 characters, additional texts up to 2000 characters, product group, sell-by-date, barcode, price overwrite, tare, VAT-rate, special offer price, special offer text, by count (=units), fixed weight, price based on kg, 100 g, lb, 1/2 lb, 1/4 lb, graduated price, timed campaigns, 3 price groups

→ **Data storage:** 7500 PLU <sup>2)</sup> with basic price and 29-digit article text, upgradable to 10 MB (optional) 32000/ PLU. Up to 120 product groups, 30 main product groups, 30 departments, 8 main departments with 20-digit text, 99 different moving promotional texts with 198 characters each, 256 vendors

→ **Dimensions mm (inches)**

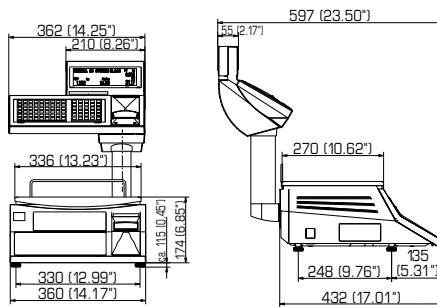

→ **SC-H 800 T-E**

→ **Thermal receipt printer** Graphic-capable printer with a speed of 102 mm/s. Printing of logos, inverted printing, upper-case or lower-case letters, EAN-/UPC barcode, 9 font sizes, up to 15 headers and base texts, optional talon.

→ **Thermal label printer** As receipt printer (except for optional talon), labels freely configurable, 2 printing directions, various label sizes, adhesive or standard receipt

→ **Linerless printer** For label rolls without backing paper

→ **Interfaces** System bus (RS 485) for network with up to 64 scales, (RS 232, licensed interface protocol) serial interface for connection to EDP or for connection of scanner or electronic-cash-terminal, control of up to two cash draws (optional), Ethernet-interface (optional), wireless IEEE 802.11 b (optional)

→ **Reports/Analyses** Number of sales periods: freely configurable (up to 99) for PLU, product groups, main product groups, VAT-rate, vendor, department, main department, training, sales volumes by department, product group, vendor, various sorting criteria, price modification journal, article modification journal, electronic receipt journal. In combination with licensed software: cashier, stock taking, re-weighing of wastage, returns, operator time recording

→ **Further features** Ticket voiding, scroll function with voiding, pay-in/pay-out mode, foreign currency conversion, function menus, various operating modes, labelling modes: Weight and fixed price, quantity preselection for automatic printout, separate sales reports, scale program loadable via interface (Flash-RAM), self and quick service, various tare modes, vendor log in and log off, operational assistance by dot matrix display, menu password protected, Bonus points and loyalty card

→ **Licensed software** Interface protocols, check-out functions, scanning, electronic-cash, operator time recording, stock taking, re-weighing of wastage, branch returns, delivery note, purchase order, return delivery, immediate invoice for cash and carry, Country of origin beef traceability

→ **Working temperature range** -10 °C to +40 °C  
14 °F to 104 °F

→ **Operating voltage** (-10 + 6 %) 230 V or (-15 + 10 %) 120 V

→ **Power consumption** at 230 V min. 125 mA / max 220 mA  
at 120 V min. 240 mA / max 440 mA

→ **Line frequency** 50/60 Hz

\*\* A SCALE WITH TWO INEGRATED PRINTERS. BIZERBA SYSTEM CLASS SC-H 800 T-E.

<sup>1)</sup>Optional <sup>2)</sup>The number of PLUs depends on the configuration of the data storage with additional functions, the memory capacity can be upgraded in stages (optional) in order to adapt to requirements.



**BIZERBA**  
\_balanced information